

## Planetary Mixers

### Planetary Mixer for Bakery, 20 Lt. - Electronic

ITEM # \_\_\_\_\_

MODEL # \_\_\_\_\_

NAME # \_\_\_\_\_

SIS # \_\_\_\_\_

AIA # \_\_\_\_\_

**600255 (XBBE20B)**

20 Lt Planetary Mixer, bowl detection device and SOLID BPA free safety screen, with 3 fixed speeds and electronic variable speed. Equipped with spiral hook, paddle, whisk and protection grid. Suitable for bakery preparation

### Short Form Specification

#### Item No.

Suitable for bakery and pastry making, for kneading, blending and whipping operations. Reinforced body for heavy duty use with 18/8 (AISI 302) 20 litre capacity stainless steel bowl. Reinforced transmission and powerful asynchronous motor (1500W) with 3 fixed speeds (40, 80, 160 rpm) and electronic variable speed (from 30 to 175 rpm). Bowl detection device allows the mixer to switch on only when the bowl and the safety screen are properly installed and positioned together. Water proof (IP55) and flat touch button control panel with a timer from 0-59 min. Pivoting and removable wire safety screen. Height adjustable feet. Kneading: speed 1 or 2 with hook; Blending speed 2 with paddle; Whipping: speed 3 with whisk. Supplied with 3 tools: spiral hook, paddle and reinforced whisk.

### Main Features

- Professional beater mixer designed to withstand the strong demands of bakery and pastry making.
- Delivered with:
  - Spiral Hook, Paddle, Reinforced Wire Whisk and Mixing Bowl for 20 Lt
- Maximum capacity (flour, with 60% of hydration) 7 kg.
- Waterproof touch button control panel with timer, speed setting and display.
- Kneading speed: "1" or "2" with hook.
- Mixing speed: "2" with paddle.
- Emulsifying speed: "3" with whisk.
- Wire safety screen fitted with a removable chute to add products while working, thus ensuring operator safety.
- Pivoting and removable wire safety screen for easier and better cleaning.
- Raising and lowering of the bowl controlled by lever with an automatic locking of the bowl when in the raised position.
- Safety device will automatically stop the machine when the bowl is lowered.
- Bowl detection device allows the mixer to switch on only when the bowl and the solid safety screen are properly installed and positioned together.
- Solid BPA-free safety screen, covering the stainless steel wire one, limits the flour and unsafe dust particles when used in bakery and pastry preparation.

### Construction

- Reinforced body, feet and transmission for heavy duty operations.
- 302 AISI Stainless steel bowl - 20 Lt. capacity.
- Water protected planetary system (IP55 electrical controls, IP23 overall machine).
- 3 fixed speeds: 40, 80 and 160 rpm.
- Power: 1500 watts.
- The solid safety screen and the stainless steel wire structure are both removable and dismantled for cleaning and are dishwasher safe.
- Adjustable feet for perfect stability.
- Electronic speed variator (10 speeds available from 30 to 175 rpm)

### Included Accessories

- |                                                    |            |
|----------------------------------------------------|------------|
| • 1 of Bowl 20 Lt mixer                            | PNC 650121 |
| • 1 of Spiral Hook 20 Lt                           | PNC 653114 |
| • 1 of Paddle 20 Lt                                | PNC 653116 |
| • 1 of Reinforced Whisk 20 Lt (for heavy duty use) | PNC 653254 |

### Optional Accessories

- |                                                                                     |            |                          |
|-------------------------------------------------------------------------------------|------------|--------------------------|
| • Bowl 20 Lt mixer                                                                  | PNC 650121 | <input type="checkbox"/> |
| • 10 Lt reduction kit (bowl, spiral hook, paddle, whisk) for 20 Lt planetary mixers | PNC 650122 | <input type="checkbox"/> |
| • Whisk 20 Lt                                                                       | PNC 653109 | <input type="checkbox"/> |

APPROVAL: \_\_\_\_\_



**Electrolux**  
PROFESSIONAL

## Planetary Mixers Planetary Mixer for Bakery, 20 lt. - Electronic

- Spiral Hook 20 lt PNC 653114
- Paddle 20 lt PNC 653116
- Reinforced Whisk 20 lt (for heavy duty use) PNC 653254
- Kit wheels for 20/30/40 litre planetary mixers (only XB models) PNC 653552



Planetary Mixers  
Planetary Mixer for Bakery, 20 lt. - Electronic

The company reserves the right to make modifications to the products without prior notice. All information correct at time of printing.

2025.11.27

Front

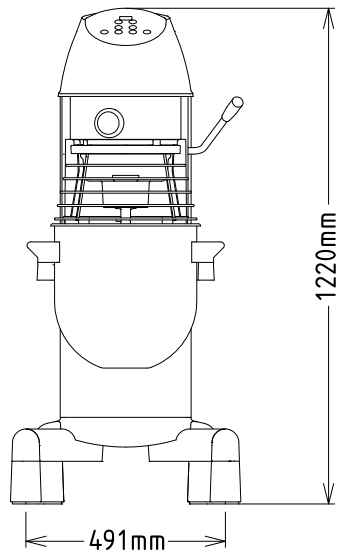

Side

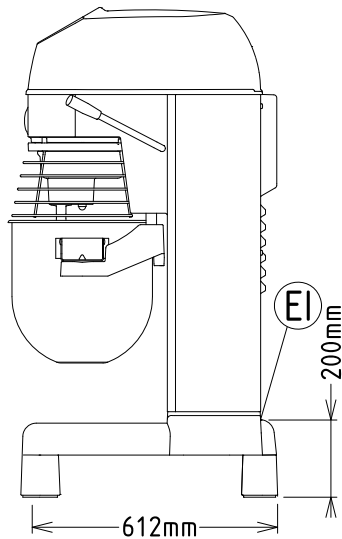

EI = Electrical inlet (power)

Top

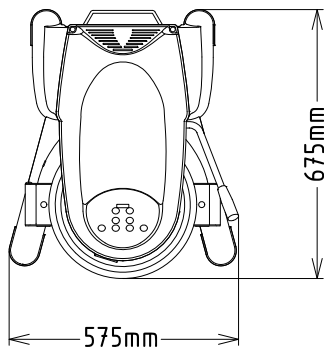
**Electric**

Supply voltage:	200-240 V/1N ph/50/60 Hz
Electrical power, max:	1.5 kW
Total Watts:	1.5 kW

**Capacity:**

Performance (up to):	7 kg/Cycle
Capacity:	20 litres

**Key Information:**

External dimensions, Width:	575 mm
External dimensions, Depth:	675 mm
External dimensions, Height:	1220 mm
Shipping weight:	111 kg
Cold water paste:	7 kg with Spiral hook
Egg whites:	32 with Whisk